

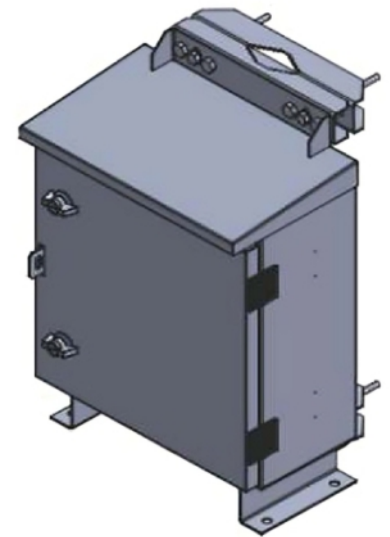

SVARN
Inspired by possibilities

DCDB

Equipment	Power Supply Circuit
Dimension	Customized As Per OEM
Mounting Arrangement	Floor Type/Wall mount/Pole mount
Colour	RAL 7035 / Customized
Ingress Protection	IP 55
Door Lock	3pt /4pt Lock & Provision Of Pad Lock
Cable Entry	Provision Of Sufficient Cable Entry Through Roxtec / Wallmax And Cable Glands
Lightning	DC CFL / LED Operated On 48V DC
Door Sealing	Provision Of Door Sealed With Proper EPDM Gasket / PU Gasket
DCDB	DCDB Arrangement Mounted On 19" Rail With Terminal Block And Earthing Busbar
Earthing	Earthing Bolts Are Provided For Earthing
Earthing (Equipment)	Provision Of Equipment Earthing Thru Suitable Busbar
Lifting Arrangement	Provision of Lifting Bracket to lift the Under Ground Vault
Grouting Arrangement on Bracket	Anchor Fastener
Manual / Labels / Stickers	Proper Labels & Sticker Are Provided
Packing	Corrugated Box



Available Range Of DCDB

Height (mm)	Width (mm)	Depth(mm)
200	250	150
250	300	150
300	300	200
400	350	200
450	450	250
550	450	300

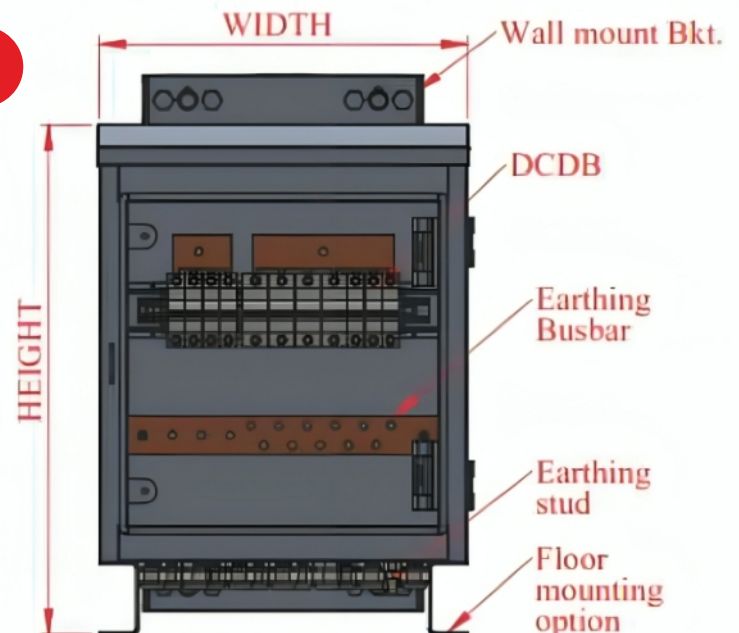

☎ 1800-121-222-999 ✉ info@svarn.com 🌐 www.svarn.com